

WETENSCHAPPELIJK ONDERZOEK BIJ HERSENTUMOREN

P.J. French

Erasmus MC



Mr. Nixon:

You can

cure cancer

If prayers are heard in Heaven, this prayer is heard the most:

"Dear God, please. Not cancer."

Still, more than 318,000 Americans died of cancer last year.

This year, Mr. President, you have it in your power to begin to end this curse.

As you agonize over the Budget, we beg you to remember the agony of those 318,000 Americans. And their families.

We urge you to remember also that we spend more each day on military matters than each year on cancer research. And, last year, more than 21 times as much on space research as on cancer research.

We ask a better perspective, a better way to allocate our money to save hundreds of thou-

sands of lives each year.

America can do this. There is not a doubt in the minds of our top cancer researchers that the final answer to cancer can be found.

Already, 4 out of about 200 types of cancer can be cured with drugs. And 37 other drugs will cause temporary remission in 17 other types of cancer.

Dr. Sidney Farber, Past President of the American Cancer Society, believes: "We are so close to a cure for cancer. We lack only the will and the kind of money and comprehensive planning that went into putting a man on the moon."

Why don't we try to conquer cancer by America's 200th birthday?

What a holiday that would be! Cancer could be then where smallpox, diphtheria and polio

are today—almost nonexistent.

If you fail us, Mr. President, this will happen:

One in six Americans now alive, 34,000,000 people, will die of cancer unless new cures are found.

One in four Americans now alive, 51,000,000 people, will have cancer in the future.

We simply cannot afford this. Our nation has the money on one hand and the skills on the other. We must, under your leadership, put our hands together and get this thing done.

Surely, the war against cancer has the support of 100% of the people. It is a war in which we lost 21 times more lives last year than we lost in Viet Nam last year. A war we can win and put the entire human race in our debt.

To the public, cancer patients, their friends and relatives:

Write or wire the President, urging him to put more funds behind cancer research. Or, please use this coupon.

Dear Mr. Nixon:

Cancer research needs more funds. Please provide them in your 1971 budget. Please.

NAME _____

ADDRESS _____

CITY _____ STATE _____ ZIP _____

Mail this coupon to: The President
The White House
Washington, D.C.

CITIZENS COMMITTEE FOR THE CONQUEST OF CANCER
888 United Nations Plaza, New York, N.Y. Solomon Gash, M.D., Emerson Fotea, Co-chairmen

12-422024

1971

Erasmus MC
Erasmus

WHY IS IT SO HARD TO CURE BRAIN CANCER

1. Cancer is highly complex
2. Gliomas cannot be completely surgically removed
3. Difficult to get drugs into the brain
4. Resistance mechanisms

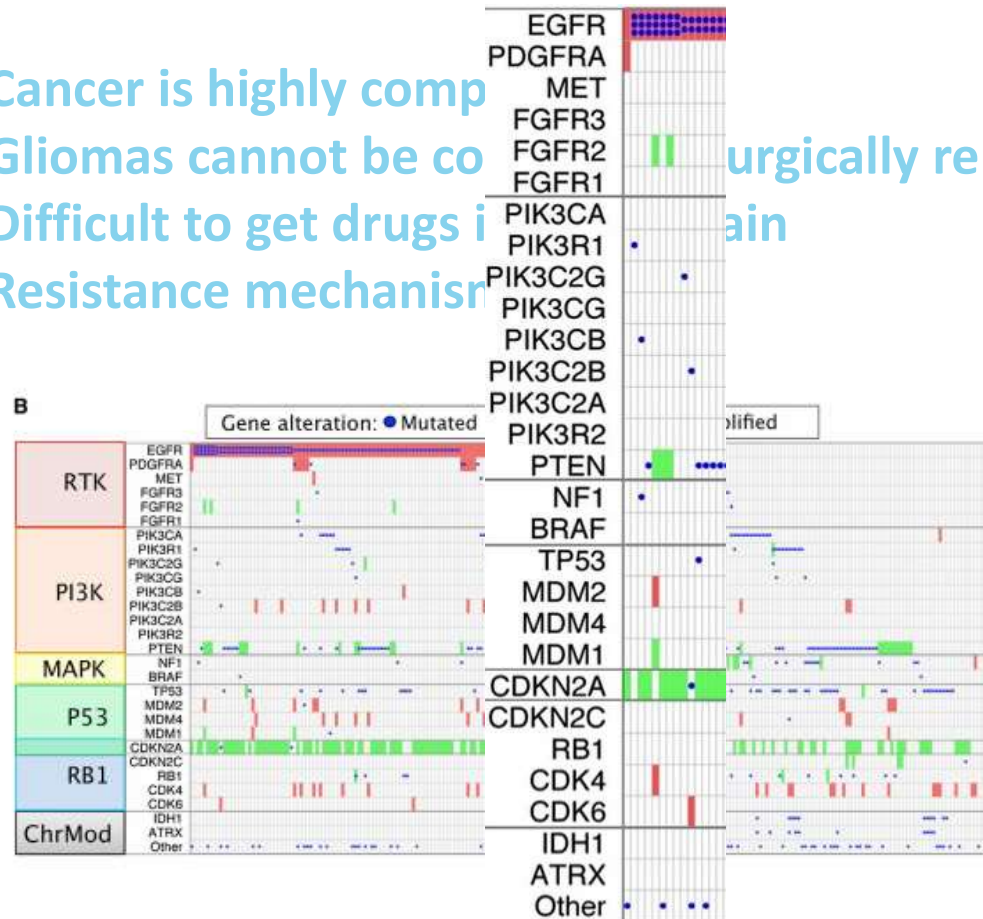

A Progression-free-Survival Population

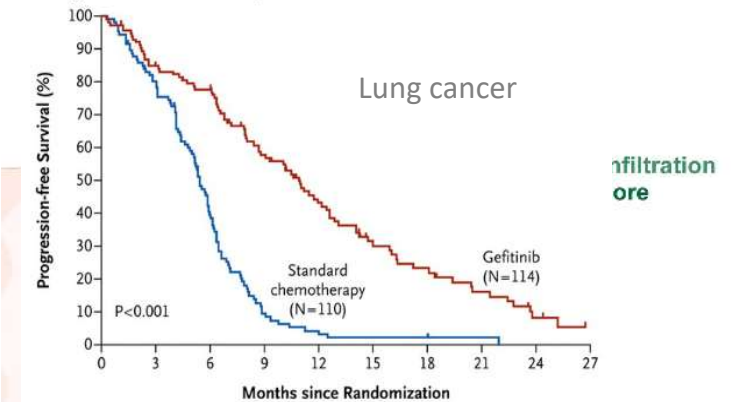

glioma cells

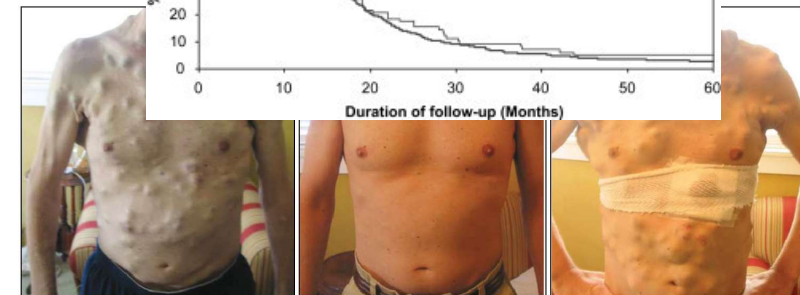
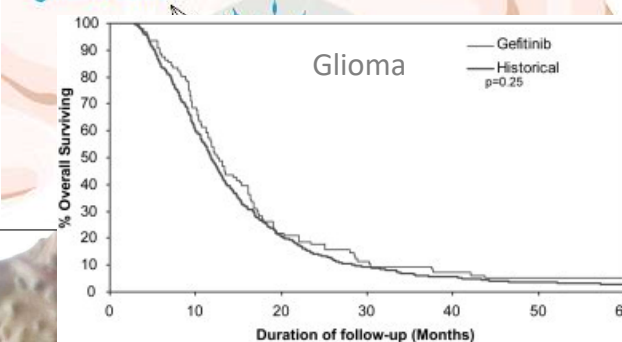

iusMC
safing

CHIRURGIE

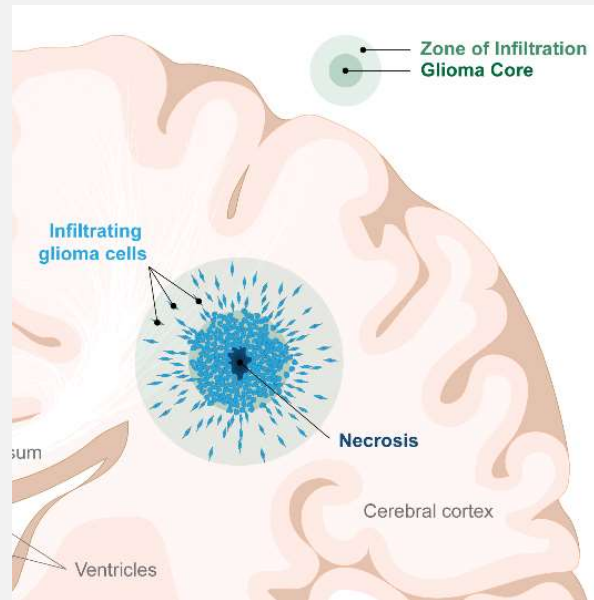

Onderzoek

Betere resectie

RADIO EN CHEMOTHERAPIE

Radiotherapie



Chemotherapie

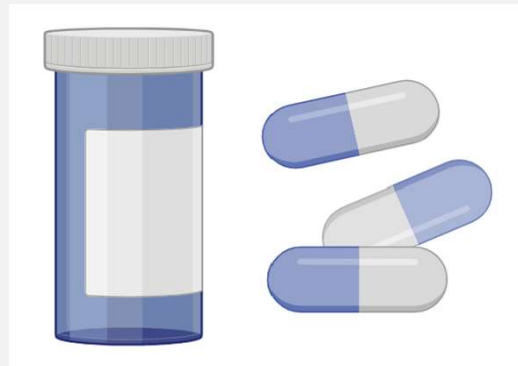

RADIO EN CHEMOTHERAPIE

Radiotherapie

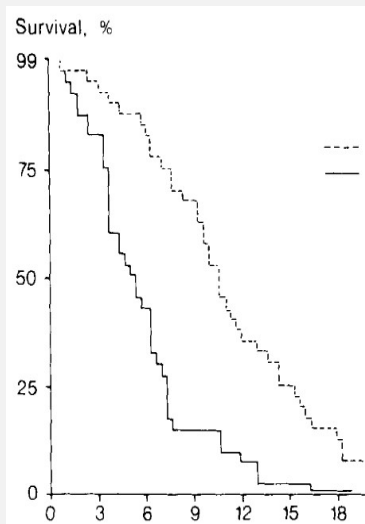

Chemotherapie

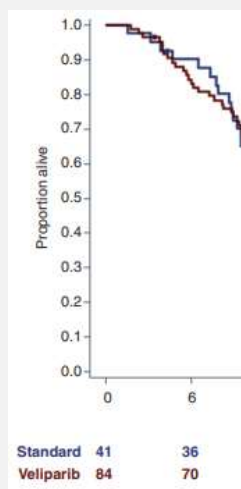

Standard 41
Veliparib 84

36
70

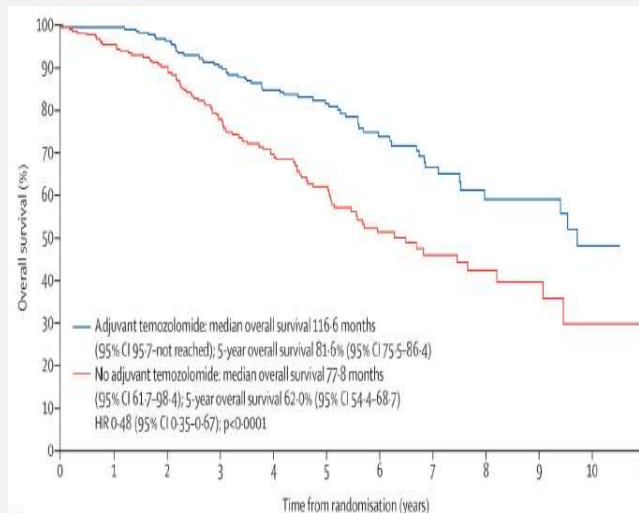

Onderzoek

Hoe ontstaat resistentie

Kunnen we daar iets aan doen:

DNA herstel remmen

EN NU?

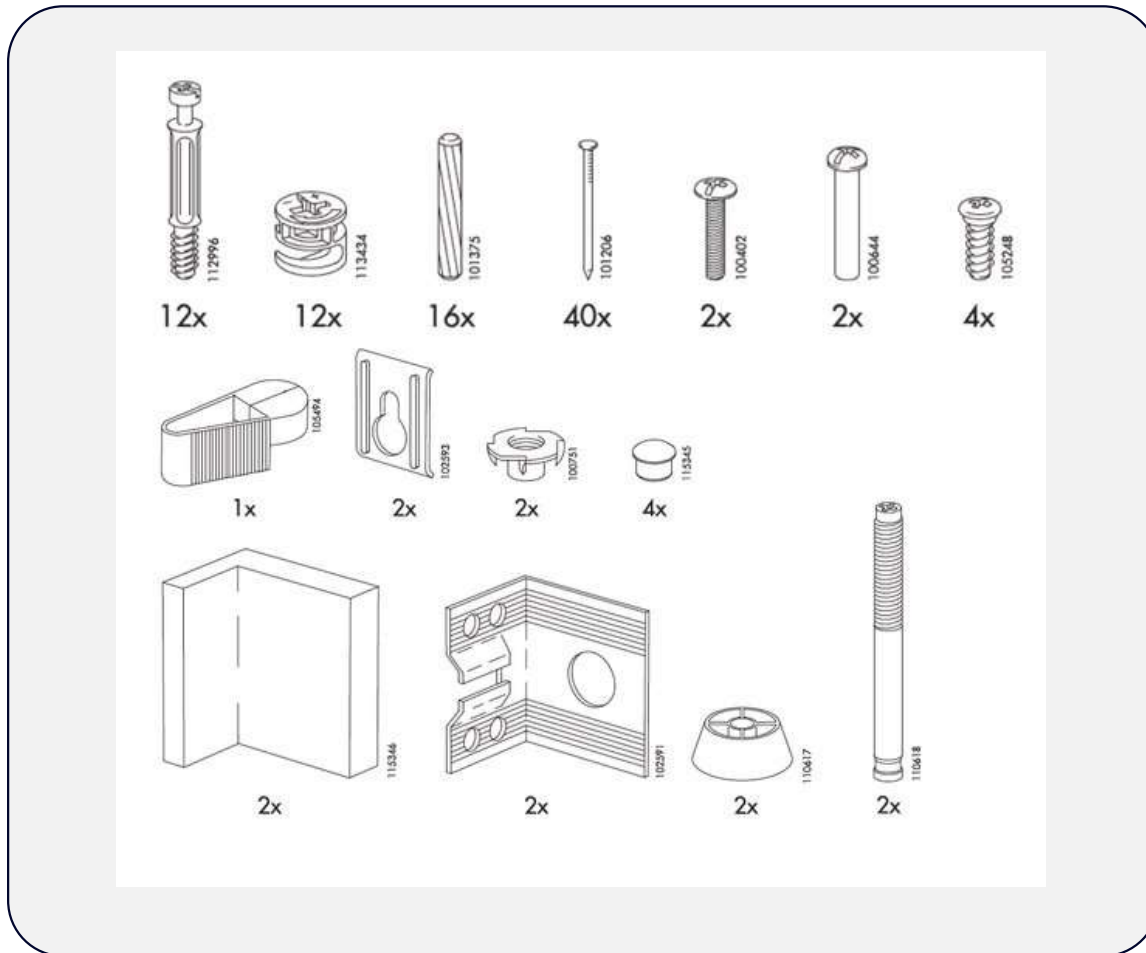

12-472024

BLOEDTOEVOER REMMEN

Remmen bloedtoevoer

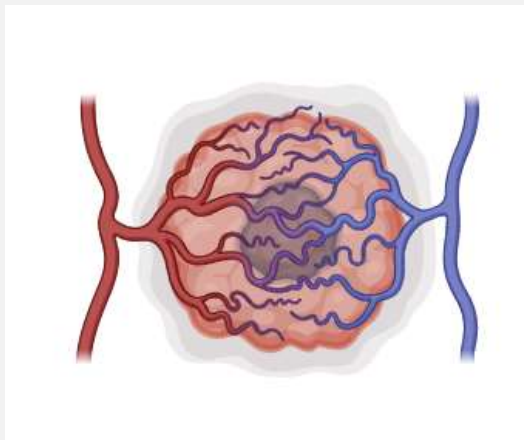

Geen effect

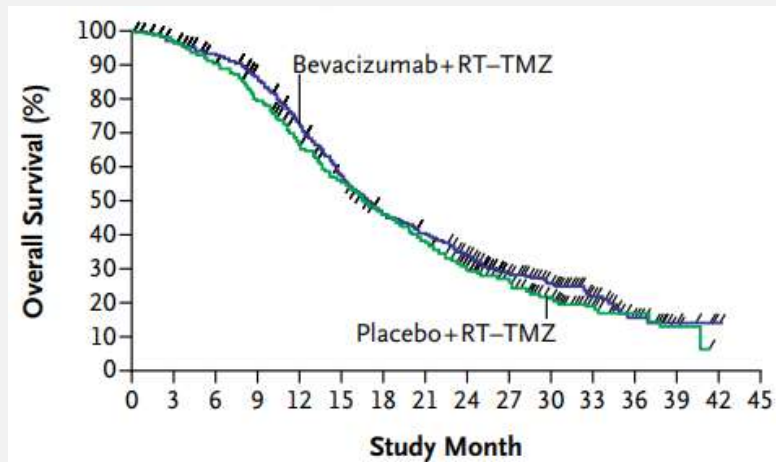

Onderzoek

Waarom?
Tumorcellen gaan op zoek naar bloedvaten

IMMUUNTHERAPIE

Checkpoint inhibitors

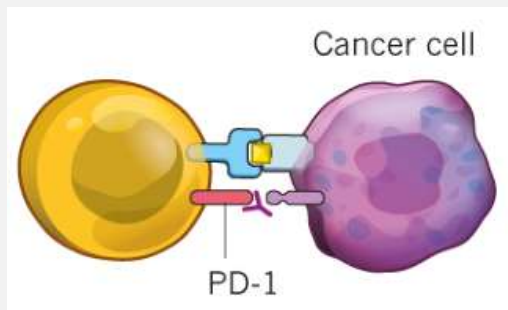

Melanomen

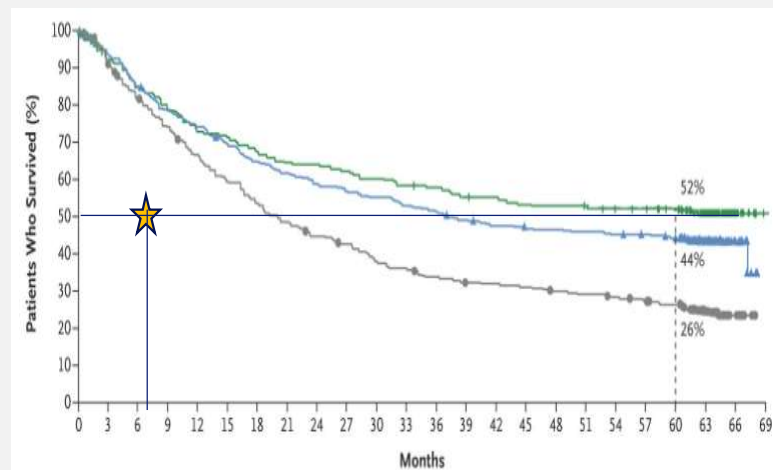

12-402024

IMMUNTHERAPIE

Checkpoint inhibitors

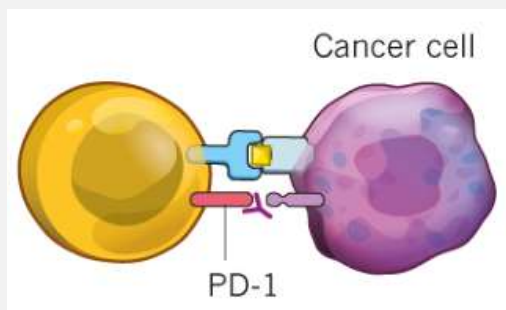

Hersentumoren

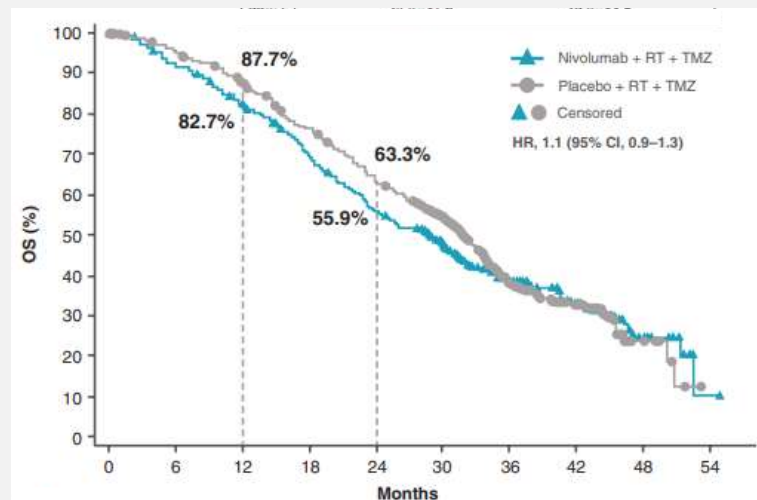

Onderzoek

Waarom?

Weinig immuuncellen in de tumor

Hoe kunnen we dit verbeteren

PRECISION MEDICINE

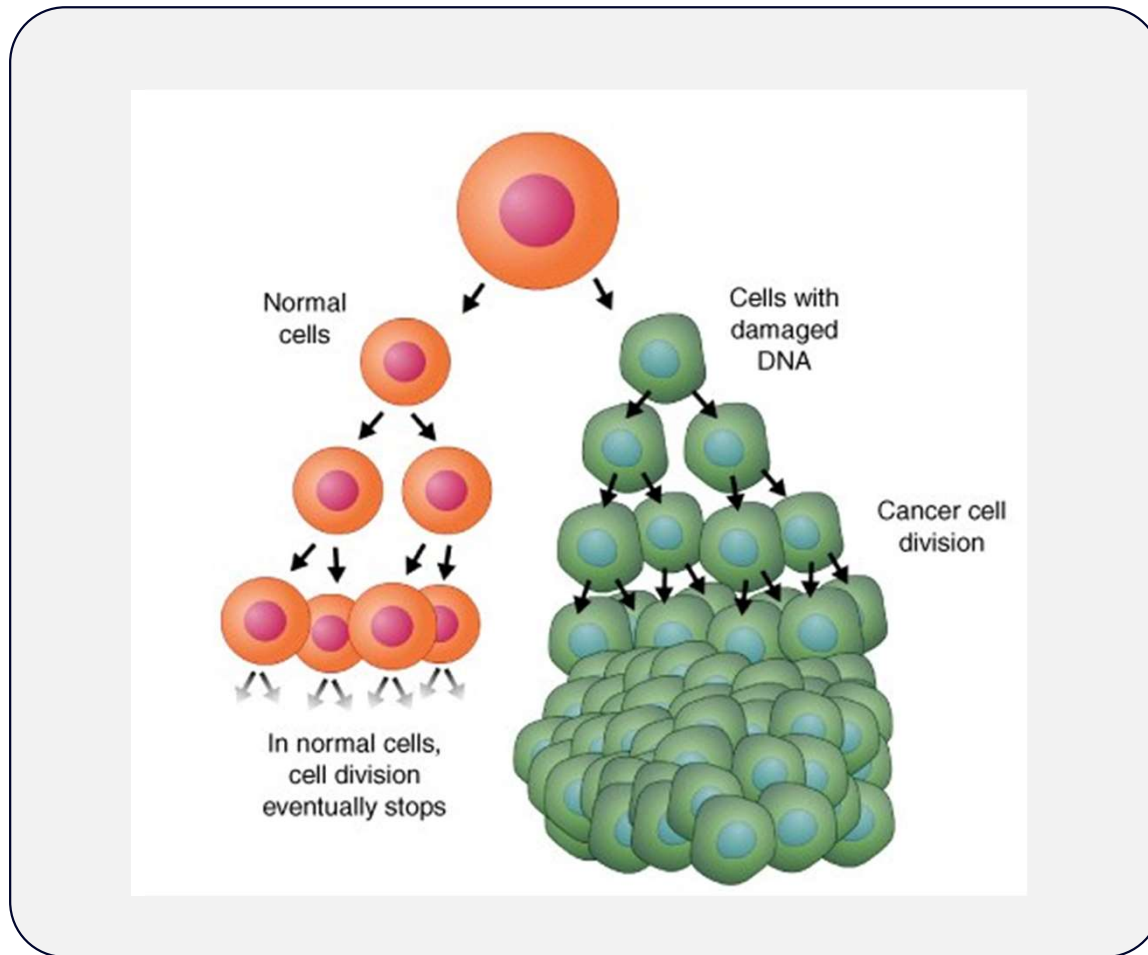

WAAROM BLIJVEN KANKERCELLEN DELEN?

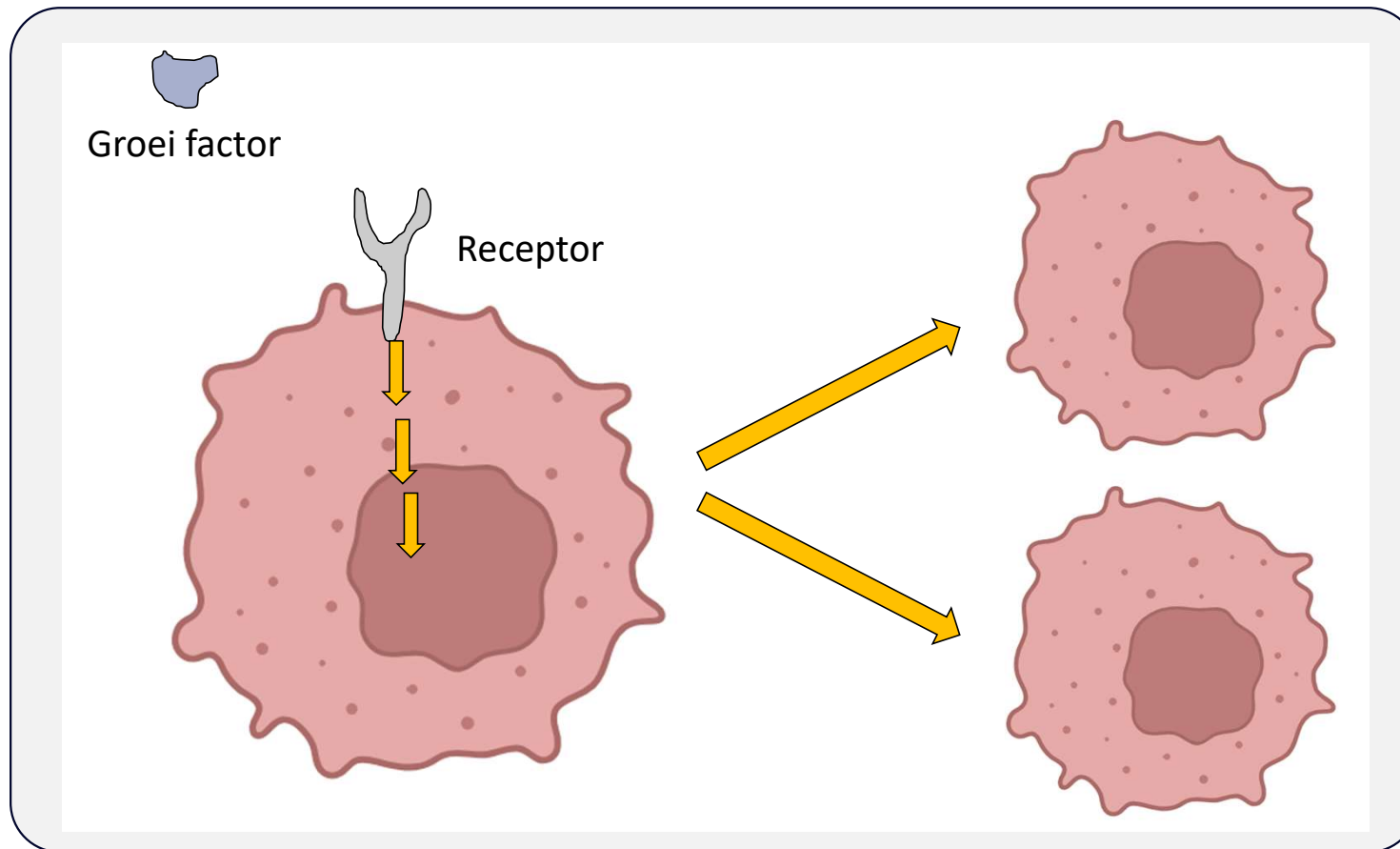

PRECISION MEDICINE

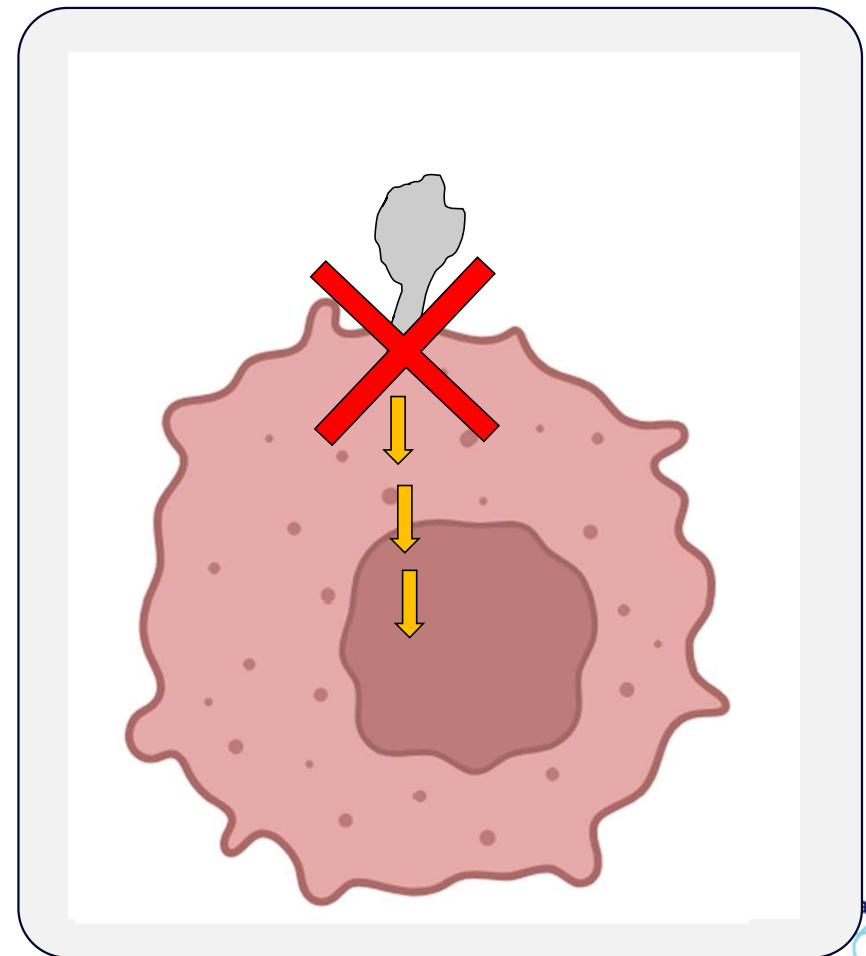
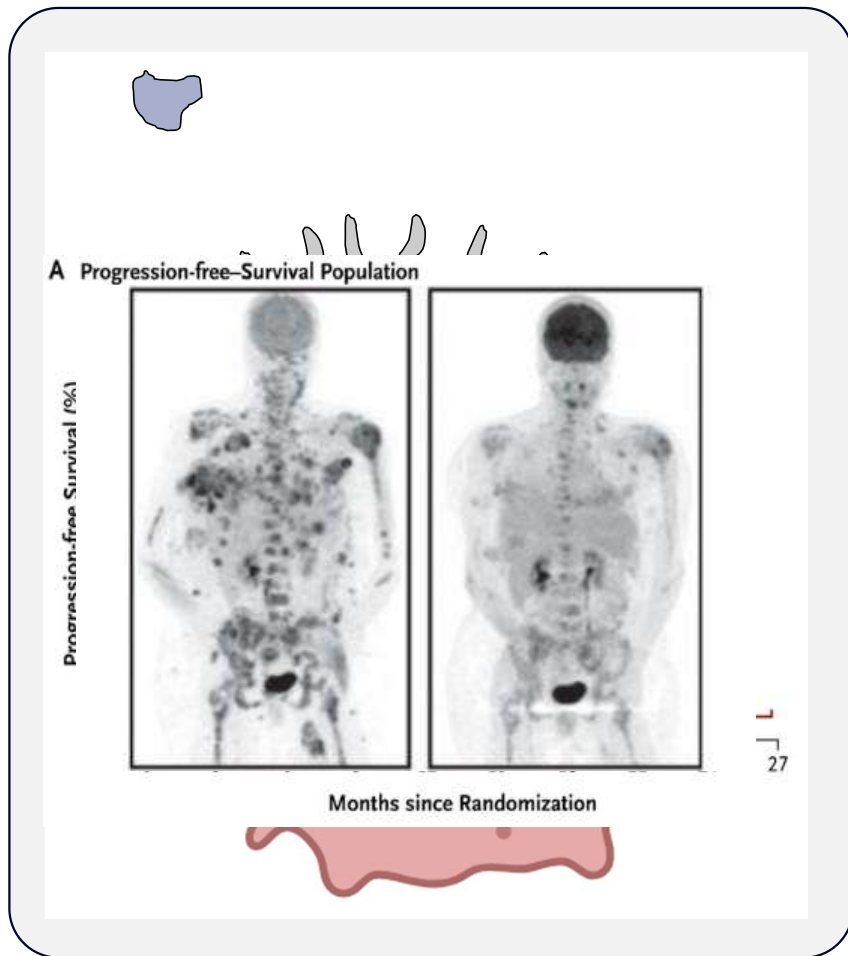

BIJ GLIOMEN...

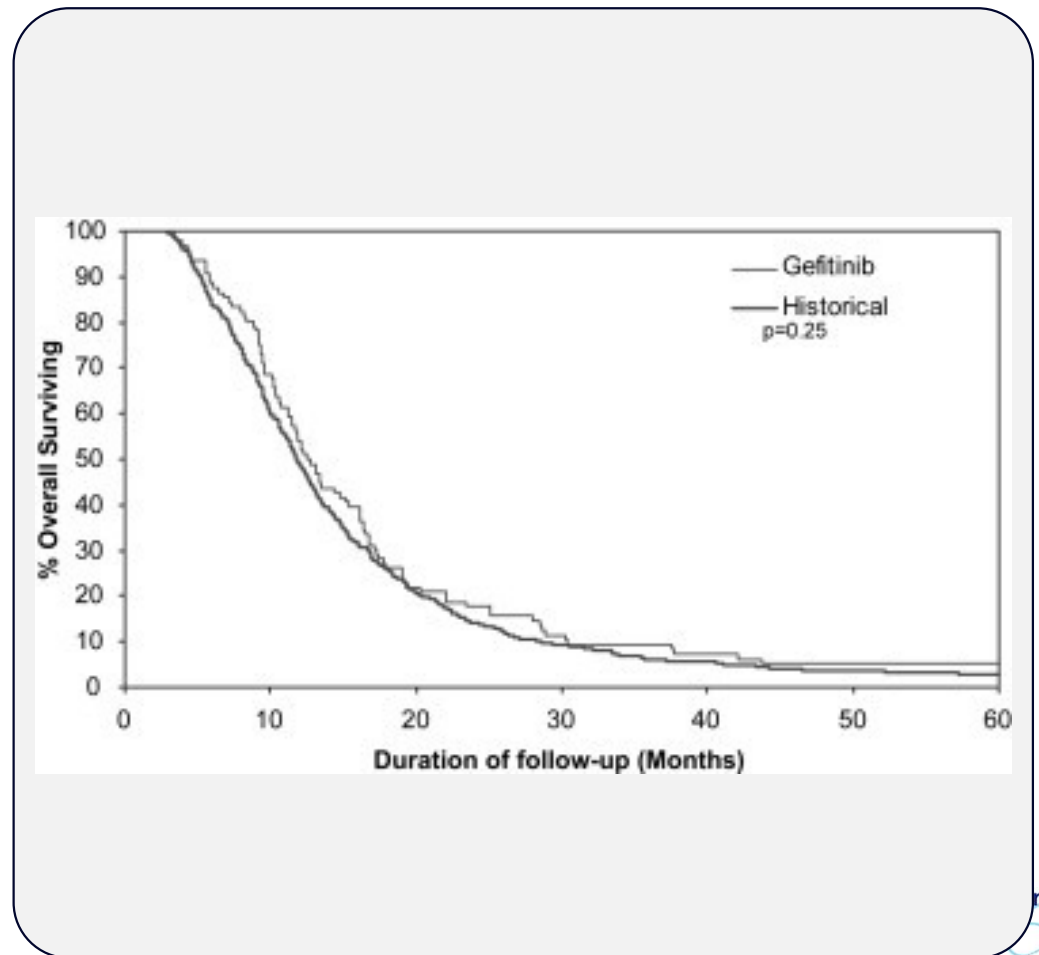
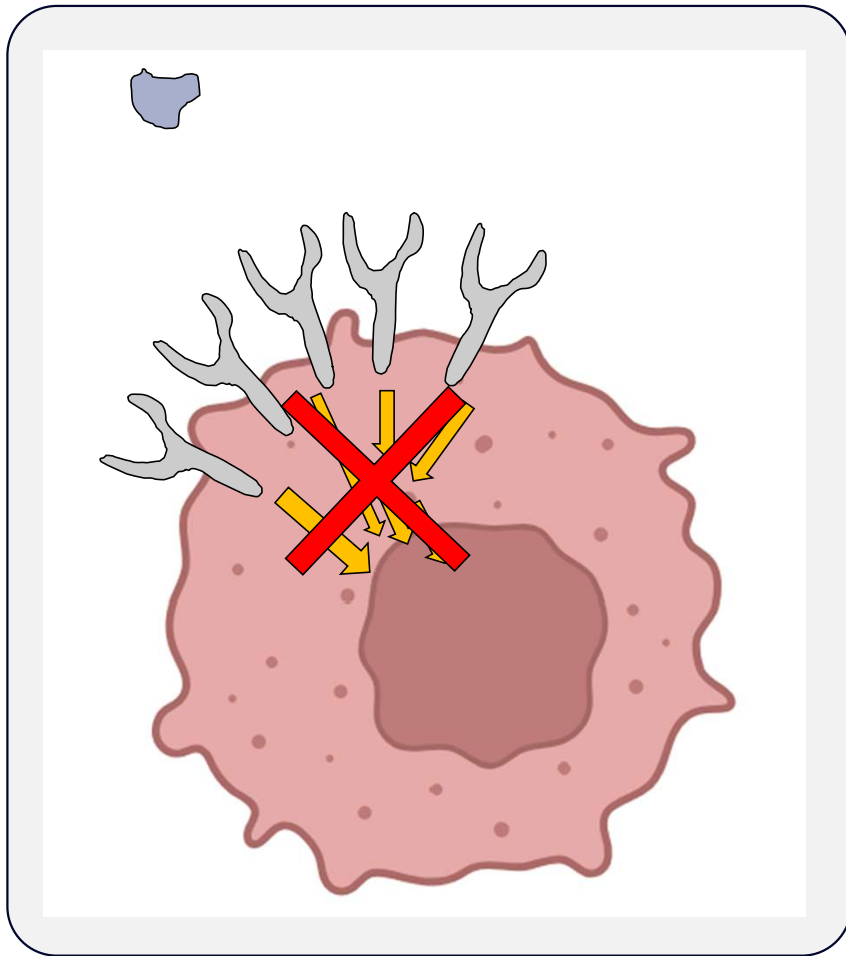

EN TOCH: IDH MUTATIES

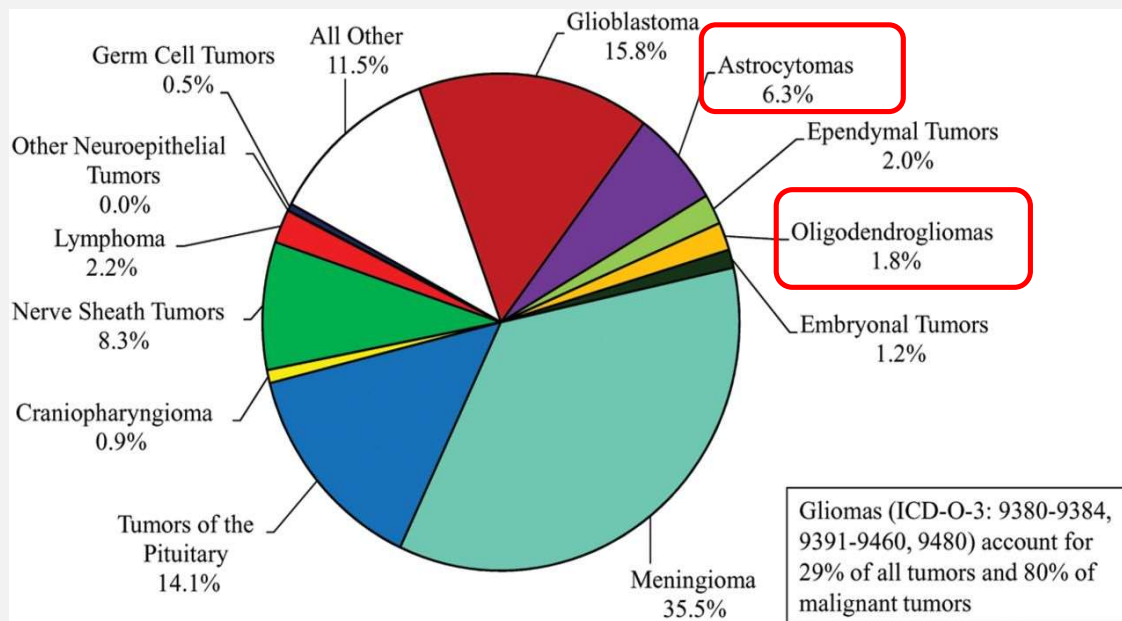

Indigo

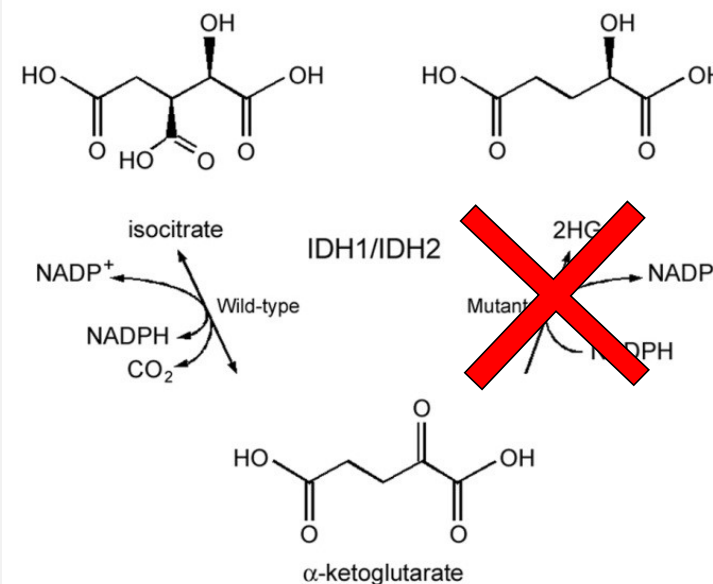

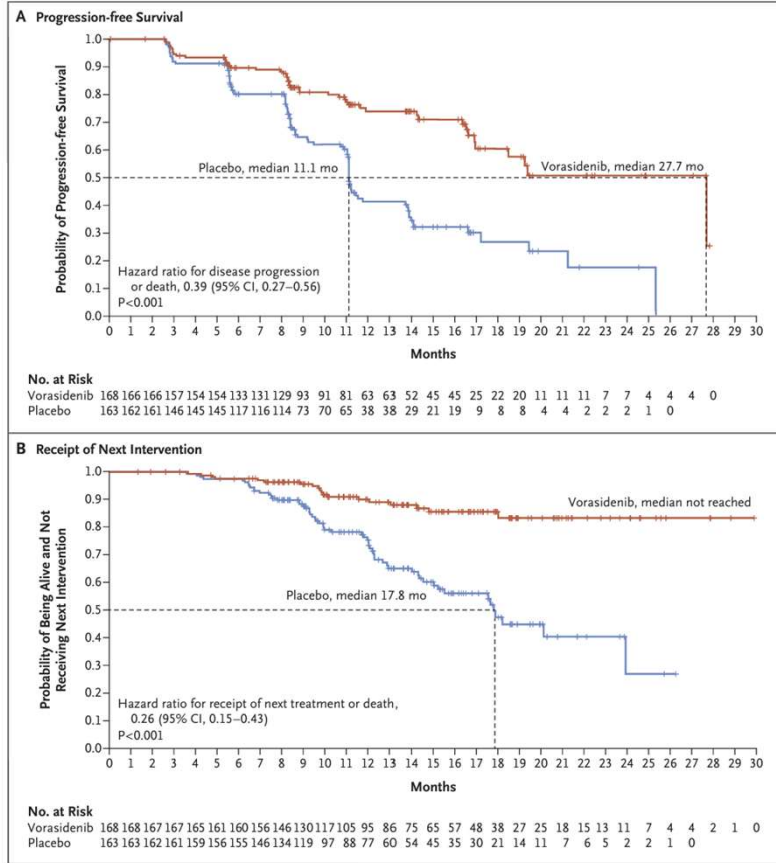

12-462024

VERVOLG ONDERZOEK

- Waarom reageren hersentumoren meestal niet op precision medicine?
- Kunnen we het immuunsysteem activeren voor hersentumoren?
- Kunnen we nieuwe manieren vinden om tumoren aan te pakken?
 - Tumor-specifieke virussen
 - Andere gevoeligheden/targets

VRAGEN?

- Heeft u wel eens gehoord van antineoplastinen?

VERVOLG ONDERZOEK

- Waarom reageren hersentumoren meestal niet op precision medicine?
- Kunnen we het immuunsysteem activeren voor hersentumoren?
- Kunnen we nieuwe manieren vinden om tumoren aan te pakken?
 - Tumor-specifieke virussen
 - Andere gevoeligheden/targets

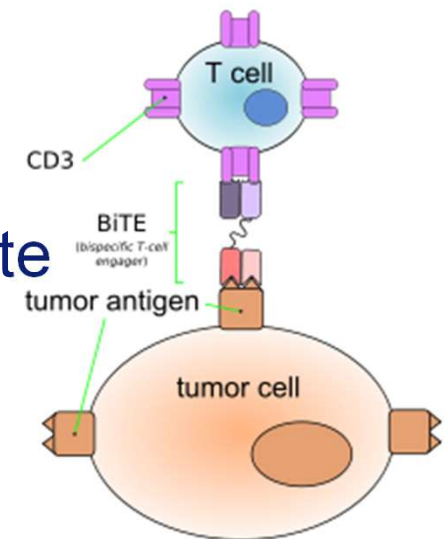
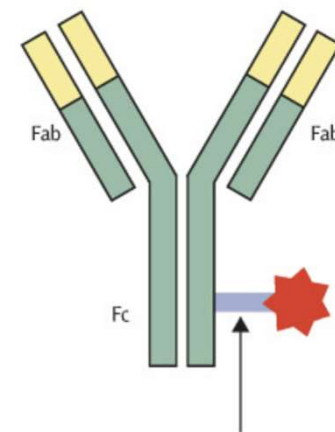

12-402024

INDIGO

- 2008: ontdekking van mutaties in IDH1 en IDH2
- 2009: ontdekking functie mutant IDH
- 2014-2018: IDH remmers in AML (ivosidenib)
- 2017-2020: IDH remmers in cholangiocarcinomen (ivosidenib)
- 2020-2022: IDH remmers in gliomen (vorasidenib)

GENETISCHE VERANDERINGEN VEROORZAKEN KANKER

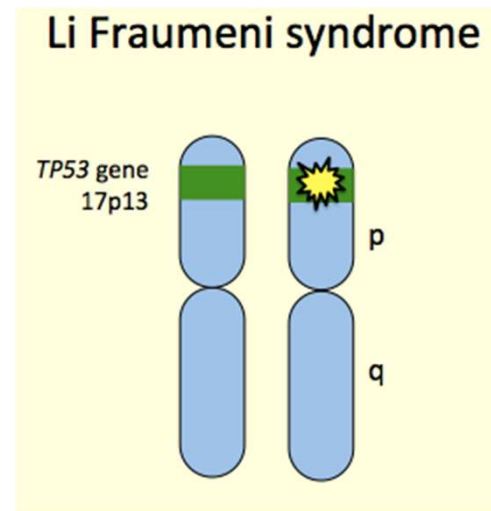
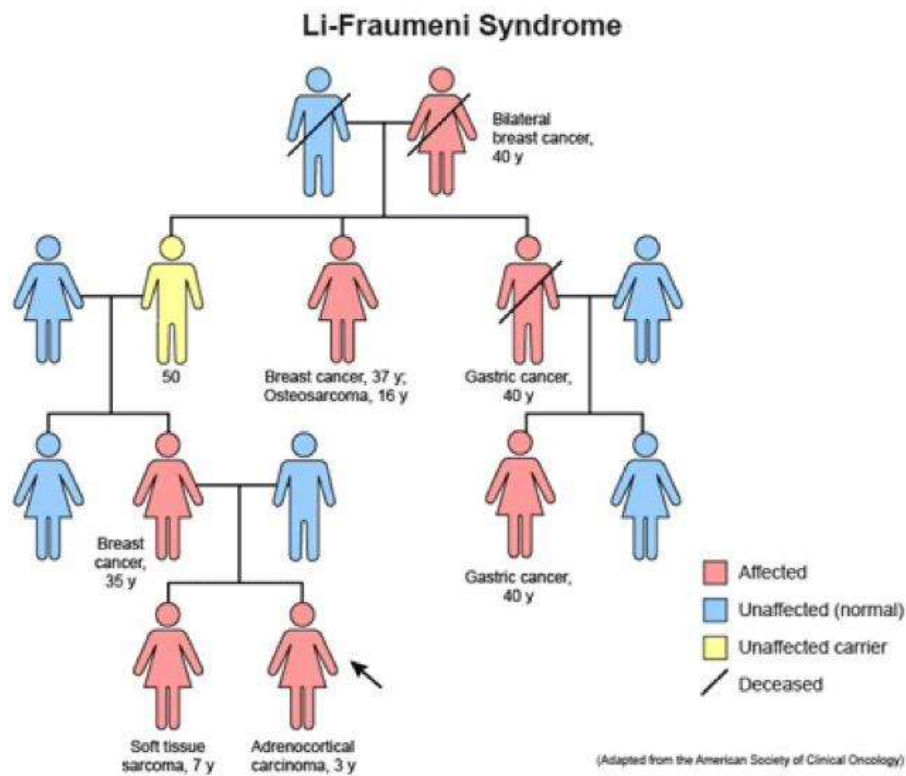

CAUSALITEIT VAN GENETISCHE VERANDERINGEN

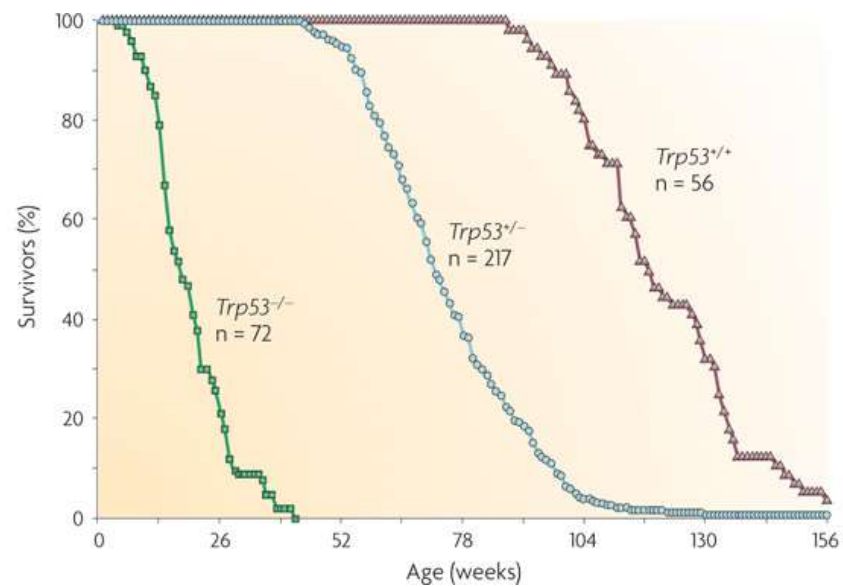
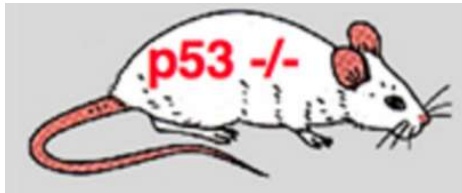

Donehower, Nat rev cancer 2009

HOE VERANDEREN START/STOP SIGNALEN



DNA:

- 2x 3.000.000.000 bouwstenen
- ~25.000 genen
 - ~100 stopsignalen
 - ~100 startsignalen

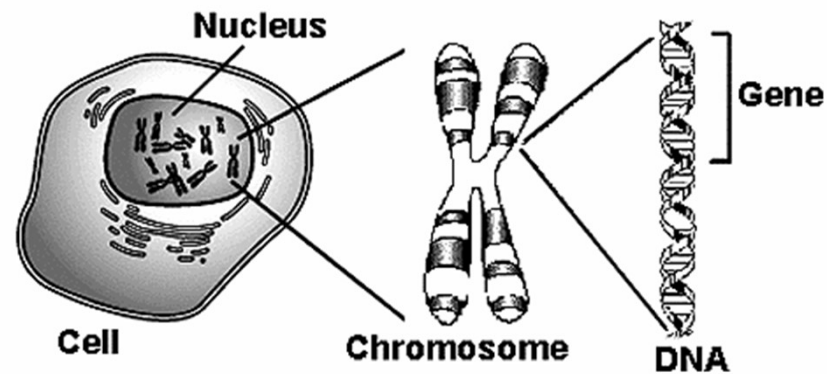

VERANDERINGEN IN DNA

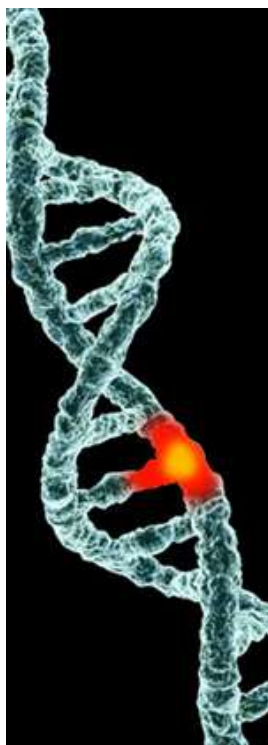

- Omgeving
 - Roken
 - Zonlicht
- Toeval
 - Leeftijd
- Erfelijk
- Veranderingen ki
- Meerdere veranderingen mogelijk ontstaan var

~150/1000 rokers krijgen longkanker
 ~13/1000 niet rokers krijgen longkanker

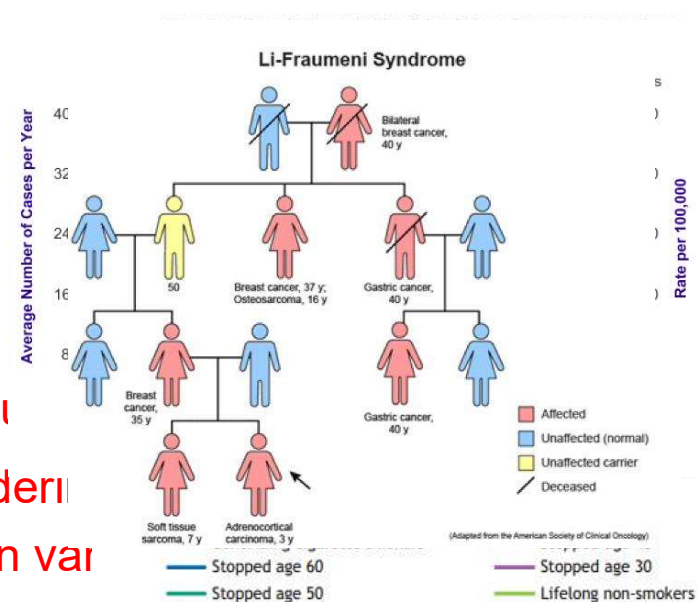

Villeneuve, Can J Public Health 1994; Petro BMJ 2000